

INTL9617 Product Brief

1. Description

The INTL9617 is a CMOS integrated circuit that provides level shifting between low voltage (0.8 V to 5.5 V) and higher voltage (2.2 V to 5.5 V) Fast-mode Plus (Fm+) I2C-bus or SMBus applications. While retaining all the operating modes and features of the I2C-bus system during the level shifts, it also permits extension of the I2C-bus by providing bidirectional buffering for both the data (SDA) and the clock (SCL) line, thus enabling two buses of 540 pF at 1MHz or up to 4000 pF at lower speeds. Using the INTL9617 enables the system designer to isolate two halves of a bus for both voltage and capacitance. The SDA and SCL pins are overvoltage tolerant and are high-impedance when the INTL9617 is unpowered. The INTL9617 is available in MSOP8 8 leads body width 3mm, This product is rated over an operating temperature range of -40 to 85°C.

2. Applications

- IT infrastructure (servers, storages)
- 5g communication
- Network system, including switches and routers

4. Functional Diagram

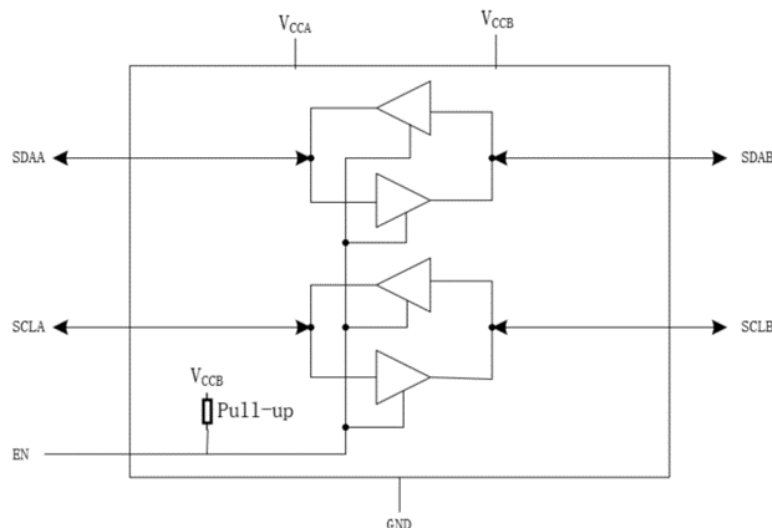

Figure 1 Functional Diagram

3. Key Features

- Two channels bidirectional I2C buffer
- Port A operating supply voltage range of 0.8V to 5.5V with normal level
- Port B operating supply voltage range of 2.2V to 5.5V with static offset level
- 5V tolerant I2C-bus and enable pins
- 0 Hz to 1000 kHz clock frequency
- Active high repeater enable input referenced to VCCB
- Latching free operation
- Open-Drain I2C I/O
- Supports arbitration and clock stretching across the repeater
- Powered-off high-impedance I2C-bus pins
- Lead-Free & Fully RoHS Compliant
- Environment-friendly without Halogen and Antimony

5. Pin Maps

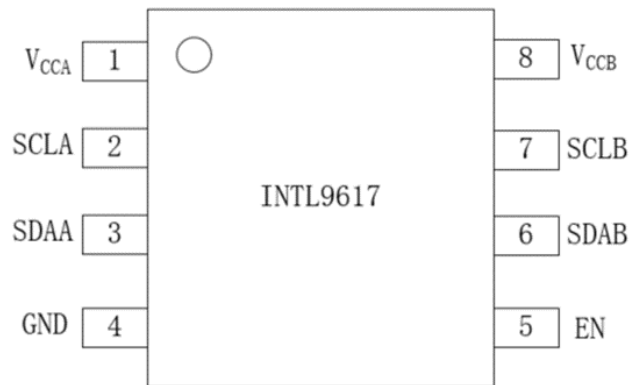

Figure 2 Pin Assignment Diagram- MSOP8

6. Pin Descriptions

Table 1 Pin Descriptions

Symbol	Pin	Description
V _{CCA}	1	port A supply voltage (0.8V to 5.5V)
SCLA	2	serial clock port A bus
SDAA	3	serial data port A bus
GND	4	supply ground
EN	5	active high repeater enable input
SDAB	6	serial data port B bus
SCLB	7	serial clock port B bus
V _{CCB}	8	port B supply voltage (2.2V to 5.5V)